

SALES DRAWING

SALES DRAWING

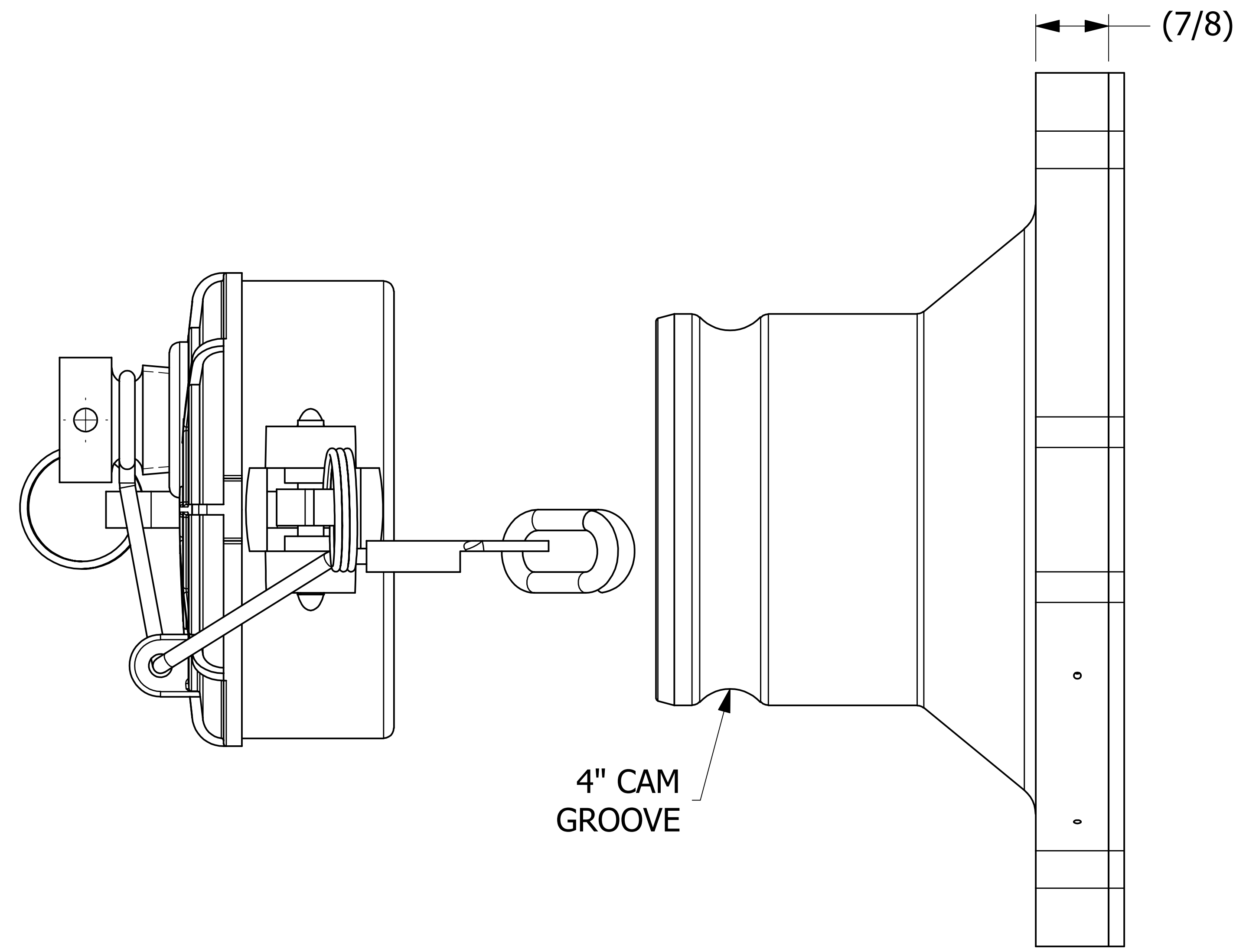
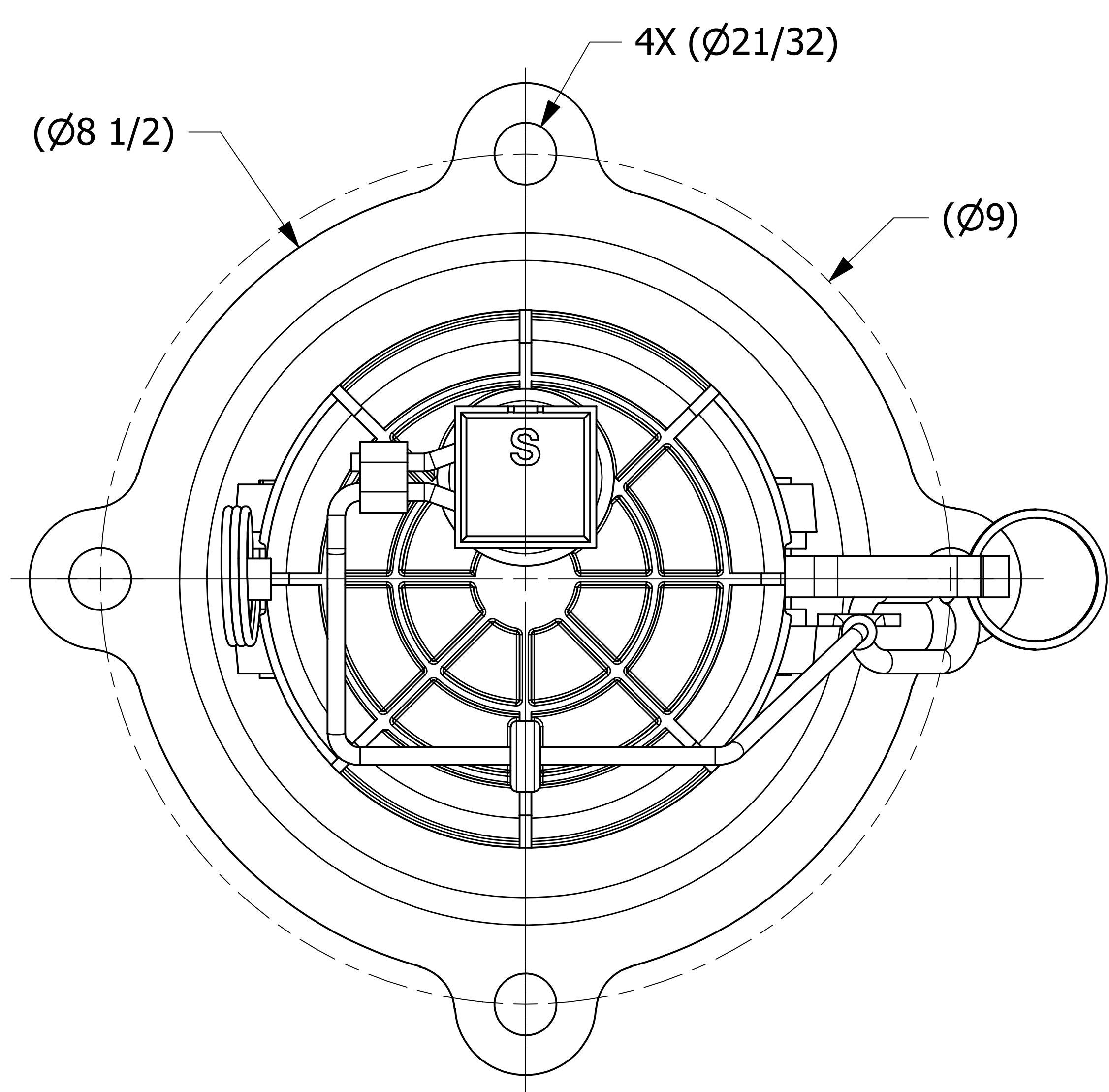

NOTES:

1. APPROXIMATE HEIGHT = 8 5/16".
2. FLANGE AAR APPROVAL# E-139514.
3. CAP AAR APPROVAL# E-139515.
4. THIS ASSEMBLY IS NOT DOT APPROVED AND CAN BE USED ONLY ON AAR STENCILED CARS.
5. CAP IS NYLON.
6. ADAPTER IS 316 SS.
7. GASKETS ARE BLACK EPDM.
8. FITS JAMESBURY 6" WAFER SPHERE VALVE (9.00" B.C.).

B	RJP	2-13-15	UPDATED TO CURRENT STANDARDS, CAP AAR# WAS E-029005B, MIL SPEC WAS MIL-C-27487G, FLANGE AAR # WAS E-039015
A	JRS	9-15-11	DRAWING ADDED TO NETWORK
REV	BY	DATE	DESCRIPTION

UNLESS OTHERWISE SPECIFIED DIMENSIONAL TOLERANCES FRACTIONAL: ±1/16 X.XX: ±.03 X.XXX: ±.015 ANGULAR: ±1° DEBURR ALL SHARP EDGES. ALL MACHINED SURFACES TO HAVE A 125 RMS FINISH UNLESS NOTED OTHERWISE. THIRD ANGLE PROJECTION	DRAWN BY:	VD
	CHECKED BY:	AJB
	PROTOTYPE BY:	VD
	PROTOTYPE DATE:	7/19/2011
	APPROVED FOR PRODUCTION BY:	AJB
	PRODUCTION DATE:	9/15/2011

SALCO PRODUCTS, INC.

UNLOADING ASSEMBLY 4" AAR FLANGE

MATERIAL: **NYLON / 316 SS**

PROJECT #: **110720** SHEET #: **1 OF 1** SCALE: **1:1**

DRAWING #: **D31089** PART #: **K4NYSWF3A**